

VZ-FMS-2 ADVANTAGES

- Full HD 1080p over coaxial cable, BNC connection
- 1/3" 2.1MP Progressive Scan CMOS Sensor
- 3G/HD-SDI, HDMI, Color Bar Signal
- Minimum Illumination 0.1 Lux (F1.2)
- ATW, ACE, AGC, Shutter Speed , HLC, BLC, DNR, WDR
- Privacy, Motion, Digital Zoom, Mirror, Flip

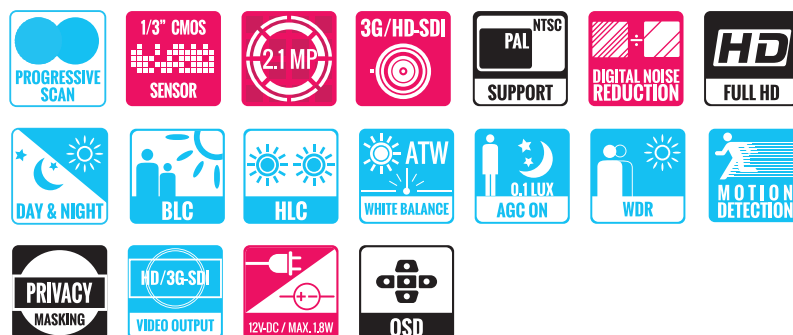

MODEL #	VZ-FMS-2
SPECIFICATION	
Imaging Sensor	2.1 Megapixel CMOS Sensor
HD Scanning System	1/3" Progressive Scan
S/N Ratio	More than 50dB (AGC Off)
HD Video Output / Resolution	HD-SDI, 3G-SDI 1080p(29.97, 59.94fps), 1080i (59.94fps), 720p (29.97, 59.94 fps) Composite(1.0Vp-p ,75ohm), Color Bar Signal
Image Frame	NTSC, PAL Composite (1.0Vp-p ,75ohm)
Min. Illumination	0.1Lux (F1.2,50 IRE,AGC MAX) / DSS X4:0.01 Lux
Horizontal TVL	More than 1000 TVL
Electronic Shutter Speed	MANUAL(1/30(25) ~ 1/30,000 sec)
S/N Ratio	More than 50dB (AGC Off)
Auto White Balance	AUTO/AUTOEXT/PRESET / Manual (R-Gain, B-Gain)
Digital Noise Reduction	DNR (Off / Low / Middle / High)
Backlight Compensation	BLC (Off / On)
Wide Dynamic-Range	WDR (Off / Low / Middle / High)
SENS-UP	OFF / x2 / x3 / x4
AGC	Adjustable 0 ~ 10
Color Temperature / R-Gain / B-Gain	Adjustable
Mirror Image	MIRROR, FLIP, (Off / On)
Privacy Masking	Support
Motion Detection	Support
Digital Zoom	Support
Camera ID	Support
INTERFACE	
HD/3G-SDI	1
DC 12V	1
WEIGHT & DIMENSIONS	
Dimensions (W x H x D)	0.9" x 0.9" x 1.45" 23.0 mm x 23.0 mm x 37.0 mm
Net Weight	0.11 lbs / 50g (Without Cable)
GENERAL	
Language	English (Selectable)
Construction	Aluminum Alloy
LENS Mount	Fix 1/2.5" 3.6mm, M12 (Option: 6mm)
Power	- Supplied Voltage DC12V 150mA - Power Consumption 1.8 W
Operating Humidity	0% to 90% Non-condensing
Operating Temperature	14 - 122 °F / -10°C ~ 50°C
Storage Temperature	-4 ~ 158°F / -20°C ~ 70°C



Application



Broadcasting App

Sports App

Medical App

Contact ViewZ

- Address : 177 W. Orangethorpe Ave., Placentia, CA 92870
- Phone : (714) 996-1177, Fax : (714) 996-1138
- Sales : sales@viewzusa.com
- Specification subject to change without notice.

DIMENSIONS

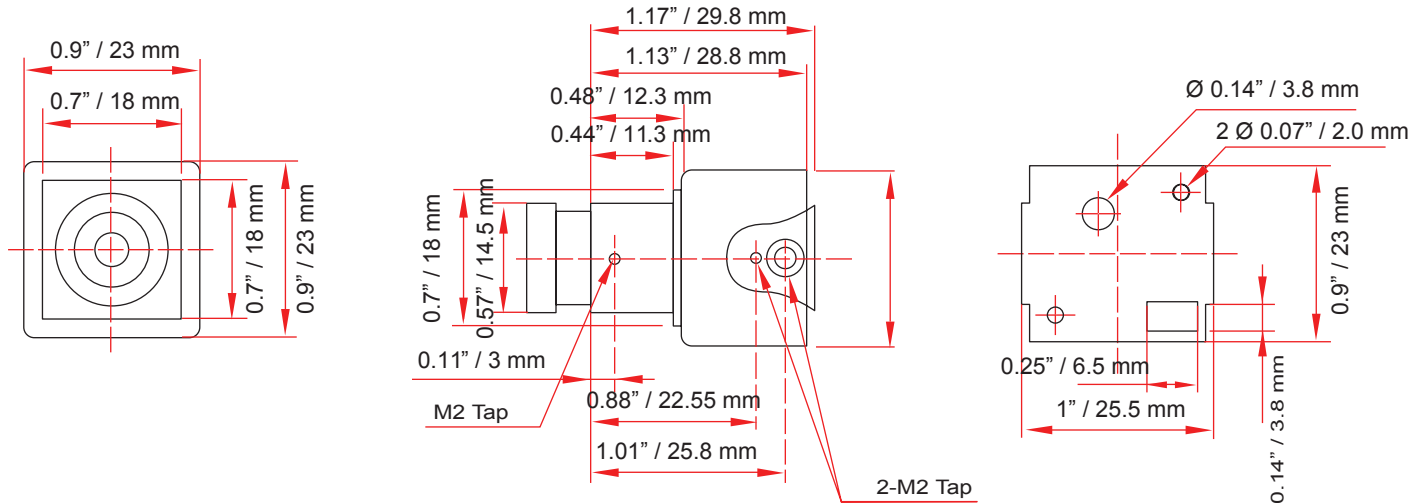

Interface / OSD Control

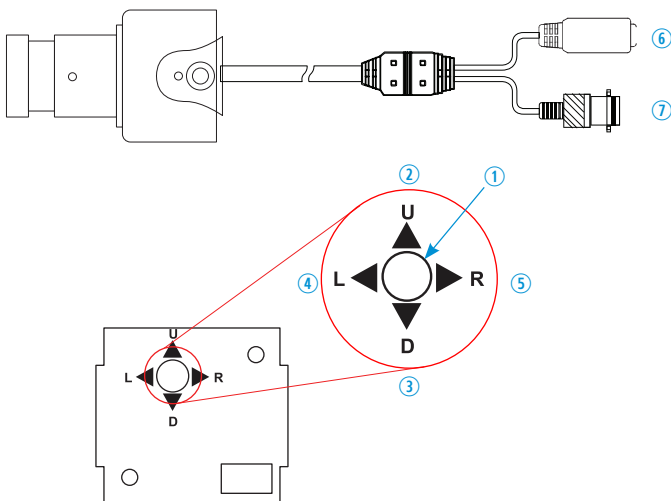

1. Set : Used to access the menu and confirm selection
2. Up : Used to move the cursor up
3. Down : Used to move the cursor down
4. Left : Used to move the cursor left and change the value
5. Right : Used to move the cursor right and change the value
6. 12V DC In
7. 3G/HD-SDI Out

Contact ViewZ

- Address : 177 W. Orangethorpe Ave., Placentia, CA 92870
- Phone : (714) 996-1177, Fax : (714) 996-1138
- Sales : sales@viewzusa.com
- Specification subject to change without notice.

HD SDI CABLE OPTION

1. DC JACK + HD SDI OUT.
2. DC JACK + HD SDI OUT + CVBS OUT (Option)