

# VZ-101FM-HB-T



## 10.1" TOUCH PORTABLE FIELD 1500 NITS MONITOR



Precision on-camera monitor with ultra high brightness and touch screen, which capable of controlling video camera menu on set. VZ-101FM-HB-T provides HDR, 3D LUT and Color Space (Built in Rec.709, EBU, SMPTE-C, DCI-P3).



The HDR let the display reproduce a greater dynamic range of luminosity, allowing lighter & darker details to be displayed clearly. Effective enhancing the overall picture quality. VZ-101FM-HB-T supports ST2084 300 / ST2084 1000 / ST2084 10000 / HLG.



Touch On-Camera Monitor with Full HD Resolution, excellent color space. Perfect gear on DSLR for taking photos.



Wider color gamut range to make precise color reproduction of Rec.709 color space with built-in 3D LUT, featuring 17 default logs & 6 user logs.



VZ-101FM-HB-T supports 1500 nits ultra high brightness for outdoor sunlight readable.

### VZ-101FM-HB-T ADVANTAGES

- HDR - support HLG, ST 2084 300/1000/10000
- 3D LUT (17 default camera logs & 6 user logs)
- Waveform / Vector Scope / Peaking / False Color / Exposure / Histogram
- Color Calibration / Gamma 1.8, 2.0, 2.2, 2.35, 2.4, 2.6 and 2.8

- 3G-SDI & HDMI Loop-through / Control Camera (Lanc Cable)
- Color Temperature (3200K/5500K/6500K/7500K/9300K/User)
- Marker / Audio Level Meter / Freeze / H/V Delay / Check Field
- Time Code / Image Flip / De-Sequence / User-Defined Button

MODEL #	VZ-101FM-HB-T
<b>DISPLAY</b>	
Screen Size	10.1" LCD
Max. Resolution	1920 x 1200
Color Space	125% BT.709 / 92.5% DCI - P3
Brightness	1500 cd/m <sup>2</sup> (Typical)
Contrast Ratio	1000 : 1
Aspect Ratio	16 : 10
Viewing Angle (H/V)	170° / 170°
HDR	HLG; ST 2084 300/1000/10000
Touch Screen	Capacitive Touch
LUT	3D LUT
<b>INTERFACE</b>	
3G-SDI In / Out	1 / 1
HDMI In / Out	1 / 1
DC 7-24 In / DC 8V Out	1 / 1
USB	1 (Firmware, 3D LUT load)
<b>INPUT FORMAT</b>	
3G-SDI	1080p / 60, 50, 30, 25, 24 1080pSF / 30, 25, 24 1080i / 60, 50 720p / 60, 50
HDMI	2160p / 60, 50, 30, 25, 24 1080p / 60, 50, 30, 25, 24 1080i / 60, 50 720p / 60, 50
<b>AUDIO</b>	
Built-IN SPEAKER	1
HDMI	1 (8ch 24 bit)
Ear Jack	1 (3.5 mm - 2ch 48 KHz 24-bit)

<b>DIMENSIONS &amp; WEIGHT</b>	
Outline Dimension ( W x H x D )	9.88 x 6.69 x 1.33" / 251 x 170 x 33.9 mm
Net Weight	1.83 lbs / 850 g
<b>GENERAL</b>	
Power	- Electrical Ratings DC 7 ~ 24V - Power Consumption ≤ 23 W (12V) / 2A
Warranty	2 Years
Operating Temperature   Humidity	32 ~ 122°F / 0 ~ 50°C   90% RH
Storage Temperature	-4 ~ 140°F / -20°C ~ 60°C
Package Include	Monitor x1, HDMI AtoC Cable x1, USB x1, Shoe Mount x1, Sunshade x1, Lanc Cable x1, F970 Battery Plate x1, Battery Plate Adapter x1, DC 12V Power Adapter x1

### Contact ViewZ

- Address : 1030 N ARMANDO ST., ANAHEIM, CA 92806
- Phone : (714) 996-1177, Fax : (714) 996-1138
- Sales : sales@viewzusa.com

# VZ-101FM-HB-T

## 10.1" TOUCH PORTABLE FIELD 1500 NITS MONITOR

### DIMENSIONS

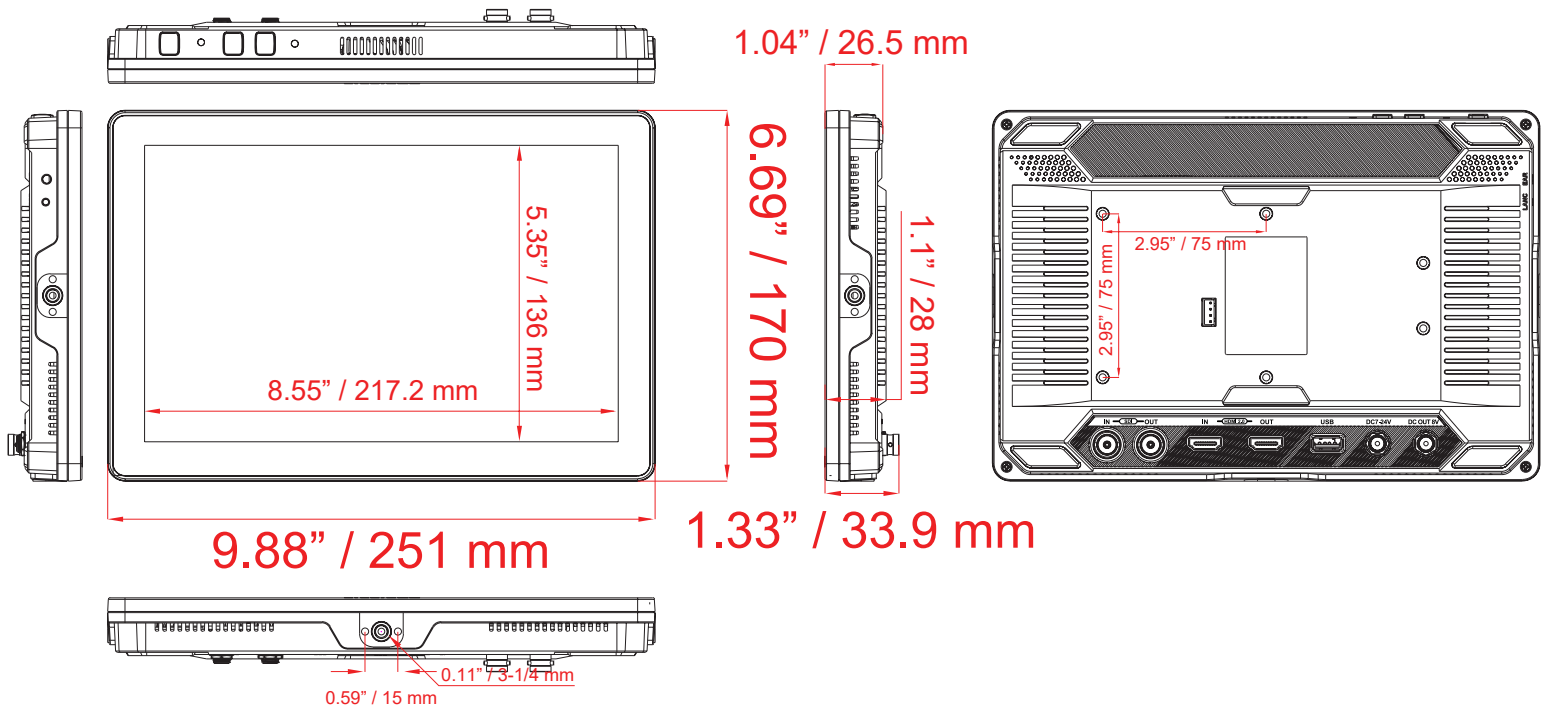

### INTERFACE

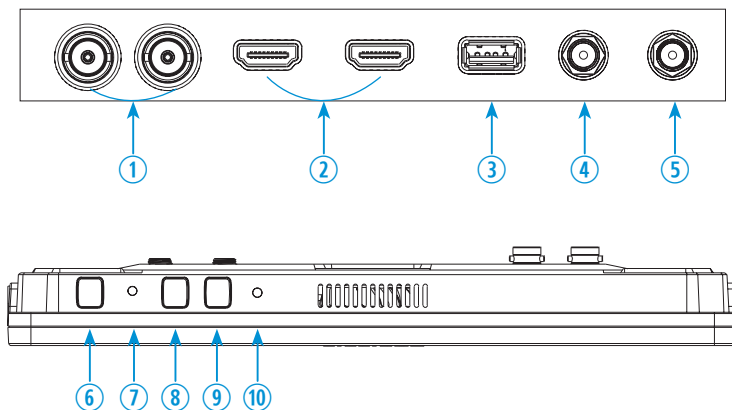

1. 3G-SDI IN / 3G-SDI OUT - Loop-through
2. HDMI IN / HDMI OUT - Loop-through
3. USB IN - 3D LUT / Firmware
4. DC 7-24V Power IN
5. DC 8V Power OUT
6. Power ON / OFF
7. Power Indicator
8. Switch Input Source
9. FN - User Defined Function Button
10. Light Sensor

### Contact ViewZ

- Address : 1030 N ARMANDO ST., ANAHEIM, CA 92806
- Phone : (714) 996-1177, Fax : (714) 996-1138
- Sales : sales@viewzusa.com