



Precision on-camera monitor with ultra high brightness and touch screen, which capable of controlling video camera menu on set.



3Gbps (3G)-SDI, higher resolution (FHD) of picture quality required Serial Digital Interface (SDI) for 1080p/60hz.



2000 nits - Ultra high brightness for outdoor sunlight readable



The HDR let the display reproduce a greater dynamic range of luminosity, allowing lighter & darker details to be displayed clearly with 2000 cd/m<sup>2</sup> panel. Effective enhancing the overall picture quality. VZ-070FM-HB supports Gamma 1.8, 2.0, 2.2, 2.35, 2.4, 2.6, 2.8.



Easy and convenient touch commands to quickly wake up the menu on screen, then adjust camera assist functions, display and settings.



Color calibration supports the PRO/LTE version of color space CMS provided by light illusion.

\* Default color calibration to 100% BT.709



Wider color gamut range to make precise color reproduction of Rec.709 color space with built-in 3D LUT, featuring 17 default logs & 6 user logs.



Display the RGB of the input video signal as a form of waves.



It presents an official standard for receiving 4K video at 60 frames per second over a cable. Equipped with HDMI 2.0 input & loop output interface which support up to 2160p 60Hz video signal.

<b>MODEL #</b>		<b>VZ-070FM-HB</b>
<b>DISPLAY</b>		
Screen Size	7" (IPS Panel)	
Max. Resolution	1920 x 1200 pixel	
Color Space	100 % BT. 709	
Brightness	2000 cd/m <sup>2</sup> (Typical)	
Contrast Ratio	1200 : 1	
Aspect Ratio	16 : 10	
HDR Supported	HLG; ST 2084 300/1000/10000	
Viewing Angle (H/V)	160° / 160°	
<b>INTERFACE</b>		
3G SDI In / Out	1 / 1	
HDMI (2.0) In / Out	1 / 1	
CAMERA (LANC) IN	1	
<b>INPUT FORMAT</b>		
3G-SDI	SMPTE 425M-Level A	1080p / 60, 50, 30, 25, 24 1080psf / 30, 25, 24 1080i / 60, 50 720p / 60, 50
HDMI		2160p / 60, 50, 30, 25, 24 1080p / 60, 50, 30, 25, 24 1080i / 60, 50 720p / 60, 50
<b>AUDIO</b>		
Built in Speaker	1 x 1W	
SDI	16ch 48kHz 24 bit	
HDMI	8ch 24 bit	
Ear Jack	3.5mm - 2ch 48kHz 24 bit	
<b>DIMENSIONS</b>		
Outline Dimension	(W x H x D) (inch)	7.32 x 5.03 x 1.3"
	(W x H x D) (mm)	186 x 128 x 33.2 mm
Net Weight		1.14 lb / 0.52 kg
<b>GENERAL</b>		
Power	Electrical Ratings	DC 7~24V (AC 100 ~ 240V)
	Consumption	≤ 16 W (15V)
Warranty	2 Years	
Operating Temperature	32 ~ 122°F / 0 ~ 50°C	
Humidity at High Operating Temperature	10 ~ 90% RH	
Storage Temperature	-4 ~ 104°F / -20 ~ 60°C	
Package Include	Manual x 1, 12V 2A DC Power Adapter x 1, HDMI A-D Cable x 1, Battery Plate Adapter x 1, Hot Shoe Mount x 1, LANC Cable x 1, Wireless Video Transmission x 1, Handbag x 1	

### VZ-070FM-HB ADVANTAGES

- 7" HD broadcast IPS 8 bit monitor with Touch Panel
- High Brightness 2000 cd/m<sup>2</sup> and Camera Control
- HDR(PQ/HLG), 3D-LUT, Waveform, Vector Scope
- Histogram, False Color, Exposure, Peaking Focus, H/V Delay, Image Flip
- De-squeeze - 1.33X, 1.5X, 1.8X and 2X
- 3G SDI 1 In / 1 Out, HDMI 2.0 1 In / 1 Out
- Marker, Freeze, Timecode, Zoom - Off, x2, x4, x6, x8
- Check Field, Audio Level Meter, 2 year warranty

### Contact ViewZ

- Address : 177 W. Orangethorpe Ave., Placentia, CA 92870
- Phone : (714)996-1177, Fax : (714)996-1138
- Sales : sales@viewzusa.com

## DIMENSIONS

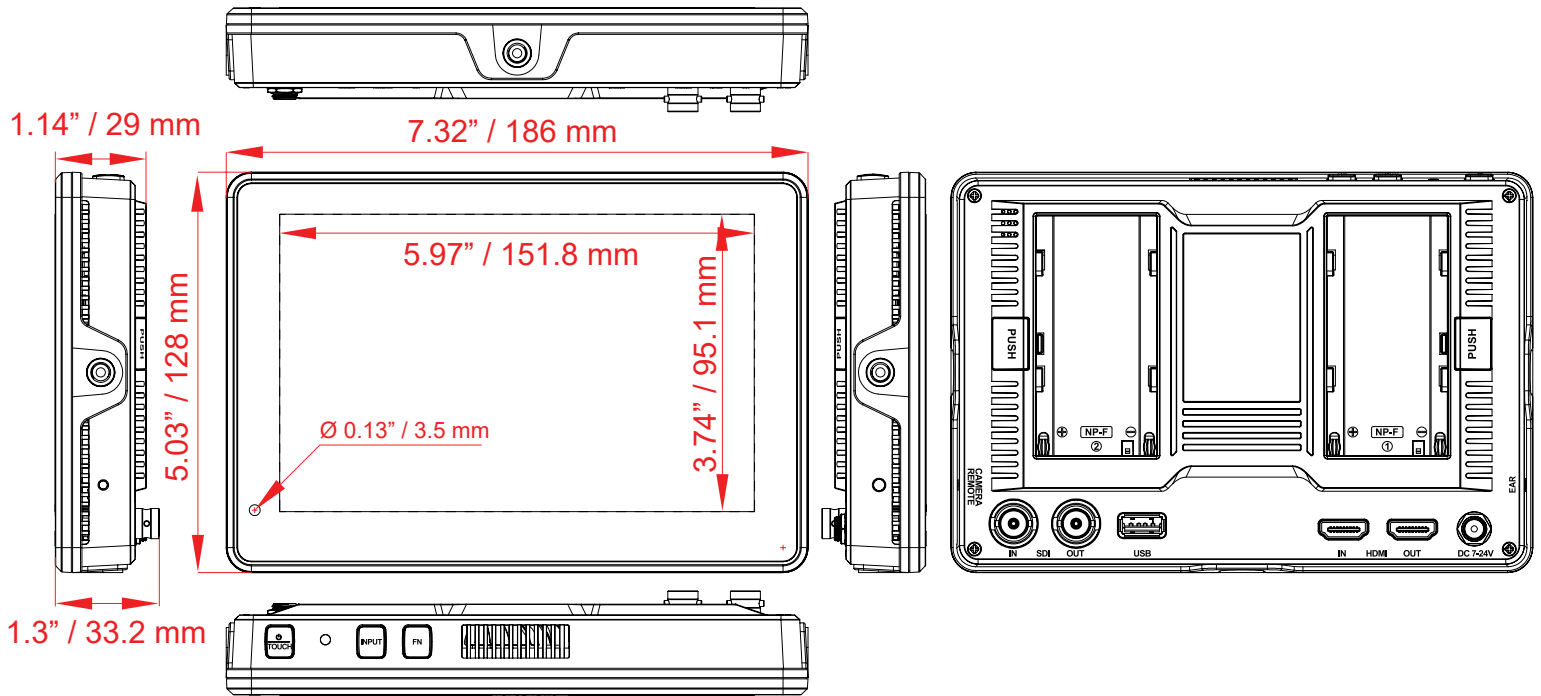

## INTERFACE

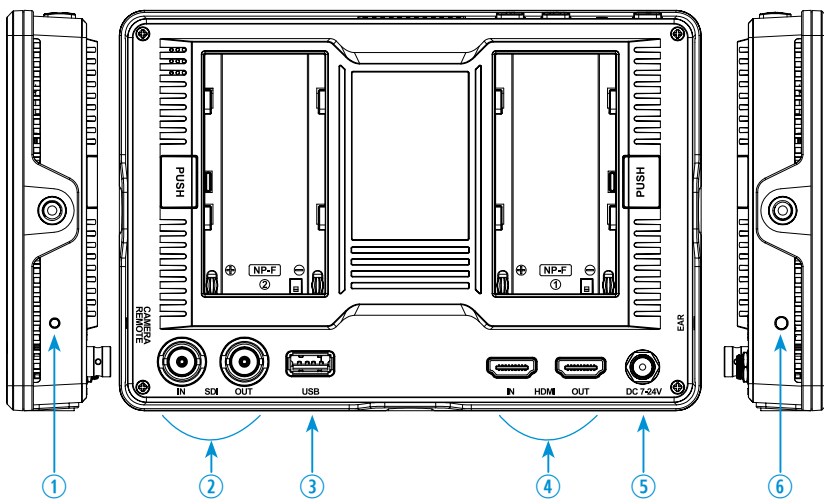

1. CAMERA REMOTE IN
2. 3G-SDI IN x OUT
3. USB IN
4. HDMI IN x OUT
5. DC 24V IN
6. AUDIO x OUT

### Contact ViewZ

- Address : 177 W. Orangethorpe Ave., Placentia, CA 92870
- Phone : (714)996-1177, Fax : (714)996-1138
- Sales : sales@viewzusa.com