

WALL MOUNT FOR 40" TO 65" MONITORS

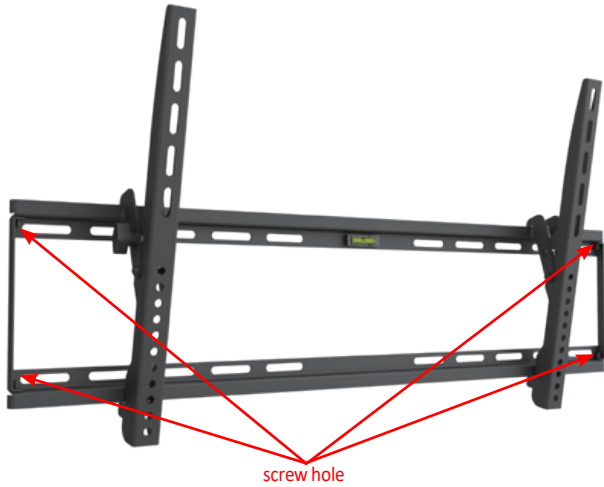

screw hole

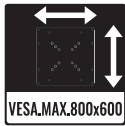
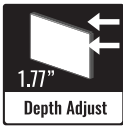

VZ-WM71 ADVANTAGES

- Combining multiple mounts for quick accurate installation
- Universal Mounting Pattern
- Fit for ViewZ Monitors 40" ~ 65"
- Weight Limit 165 lbs (75.0 kg)
- -10° ~ 0° tilting
- 3 Year Warranty

DIMENSIONS

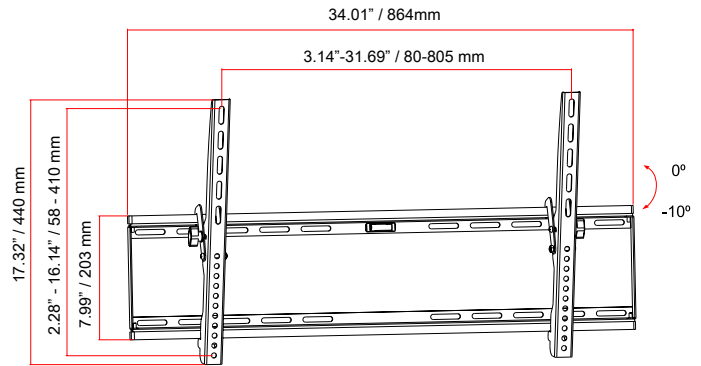

APPLICATION DESIGN

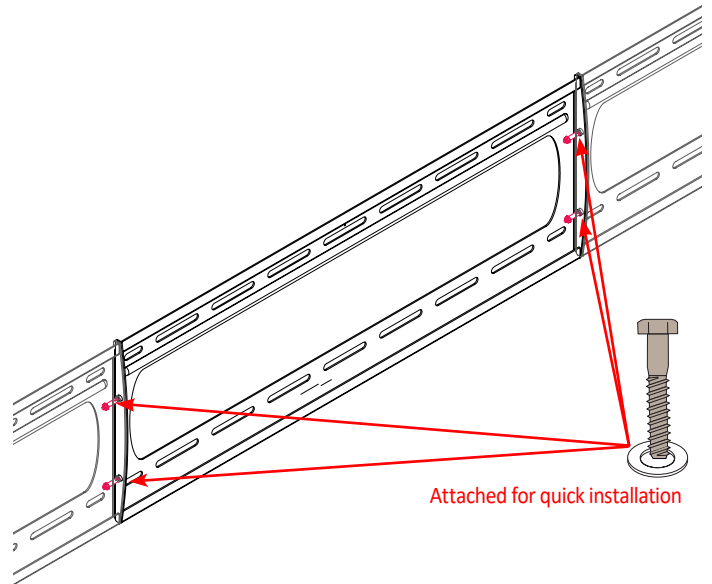

MODEL #	VZ-WM71
FEATURES	
Net Weight	6.35 lbs / 2.88 kg
Weight Capacity	165 lbs / 75.0 kg
Dimension (Width x Height x Depth) inch	34.01 x 17.32 x 1.97
(Width x Height x Depth) mm	864.0 x 439.93 x 50.03
Mounting Pattern Type	Universal / VESA
Display Range	40" ~ 65"
Tilt	-10° ~ 0°
Profile	1.97" / 50.03 mm

PRECAUTIONS

- Do not exceed rated & listed weight. Serious injury or property damage may occur !
- Do not begin the installation until you have read and understood all the instructions and warnings contained in this installation sheet. If you have any questions regarding any of the instructions or warnings, please contact your local distributor.
- This mounting bracket was designed to be installed and unlisted ONLY as specified in this manual. Improper installation of this product may cause damage or serious injury.
- Tighten screws firmly, but do not over tighten. Over tightening can cause damage to the items, This greatly reduces their holding power.
- This product is intended for indoor use only. Using this product outdoors could lead to product failure and personal injury.

* Design and specifications are subject to change without notice.

Contact ViewZ

- Address : 177 W. Orangethorpe Ave., Placentia, CA 92870
- Phone : (714) 996-1177, Fax : (714) 996-1138
- Sales : sales@viewzusa.com