

VZ-FSM3X2

3x2 VIDEO WALL DISPLAY MOUNT FOR 49" TO 55"

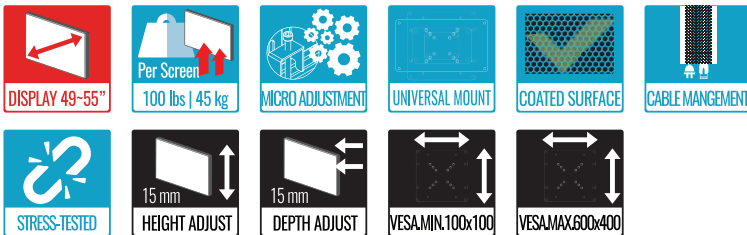
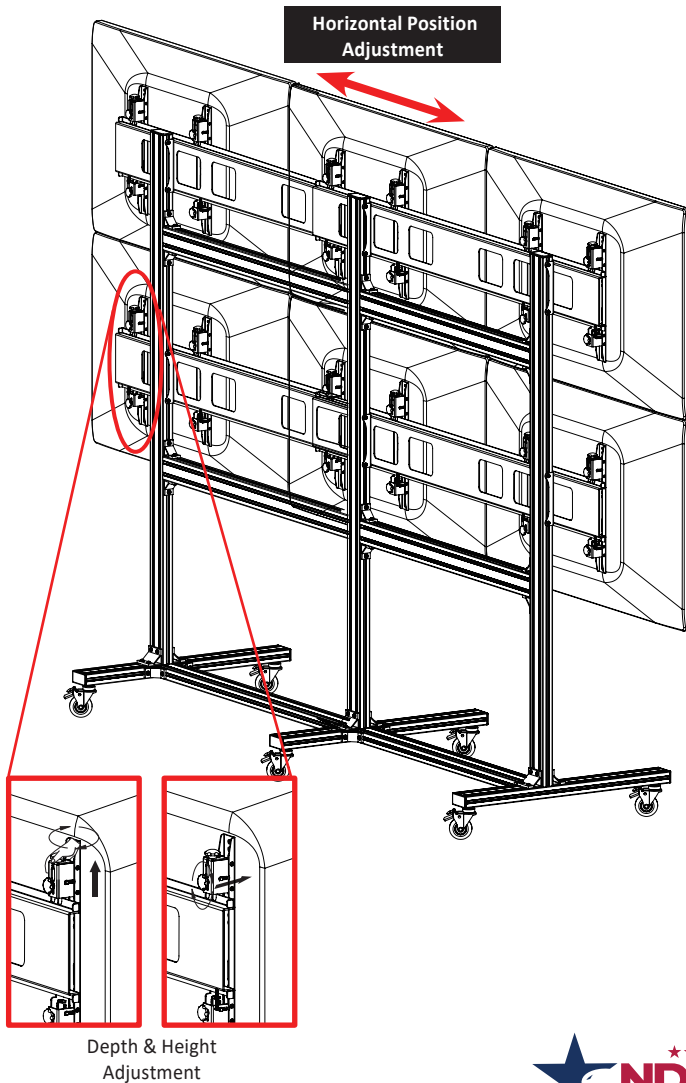

VZ-FSM3X2 ADVANTAGES

The ViewZ **FSM3X2** mount is a customizable video wall extending flat-panel mount for displays weighing up to 100 lb / 45.35 kg with a mounting pattern of 100 x 100 to 600 x 400 mm. It features **multi-monitor stacking**, **open design** and top **adjustable mounting brackets** without the need to disassemble the cart.

- 1x2, 2x2 or 3x2 Video Wall Mount
- X, Y and Z axis fine tune adjustment system allows for easy and accurate installation
- Works with flat-panel mounts that have a VESA pattern MIN. 100 x 100 mm, MAX. 600 x 400mm
- Fit for ViewZ Monitors 49 ~ 55"
- 15 mm depth & height adjustment
- 3 Year Warranty

Designed specifically for

- VZ-49/55/65UHD** 49, 55 & 65" 4K UHD Quad View Monitor
- VZ-49/55UNBS** 49 & 55" Ultra Narrow Bezel (1.2 mm) Monitor
- VZ-55EHB/ENB** 55" Extreme Narrow Bezel (0.9 mm) Monitor
- VZ-55SHB/SNB** 55" Super Narrow Bezel (0.44 mm) Monitor

PRECAUTIONS

Do not exceed rated & listed weight. Serious injury or property damage may occur !

Do not begin the installation until you have read and understood all the instructions and warnings contained in this installation sheet. If you have any questions regarding any of the instructions or warnings, please contact your local distributor.

MODEL #	VZ-FSM3X2	
	FEATURES	
Net Weight	TBD	
Total Weight Capacity	600 lbs / 272.15 kg	
Weight Capacity per Screen	100 lbs / 45.35 kg	
Dimension (Width x Height x Depth) inch	119.74 x 77.21 x 31.88"	
(Width x Height x Depth) mm	3041.5 x 1961.3 x 810 mm	
Mounting Pattern Type	Universal / VESA	
Universal Pattern	Range	
VESA Patterns	100 x 100 (Min) to 600 x 400 (Max) mm	
Display Range	49.0 ~ 55.0"	
Horizontal / Vertical Range of Each Monitor	0.59" (15 mm) / 0.59" (15 mm)	

VZ-FSM3X2

3x2 VIDEO WALL DISPLAY MOUNT FOR 49" TO 55"

DIMENSION

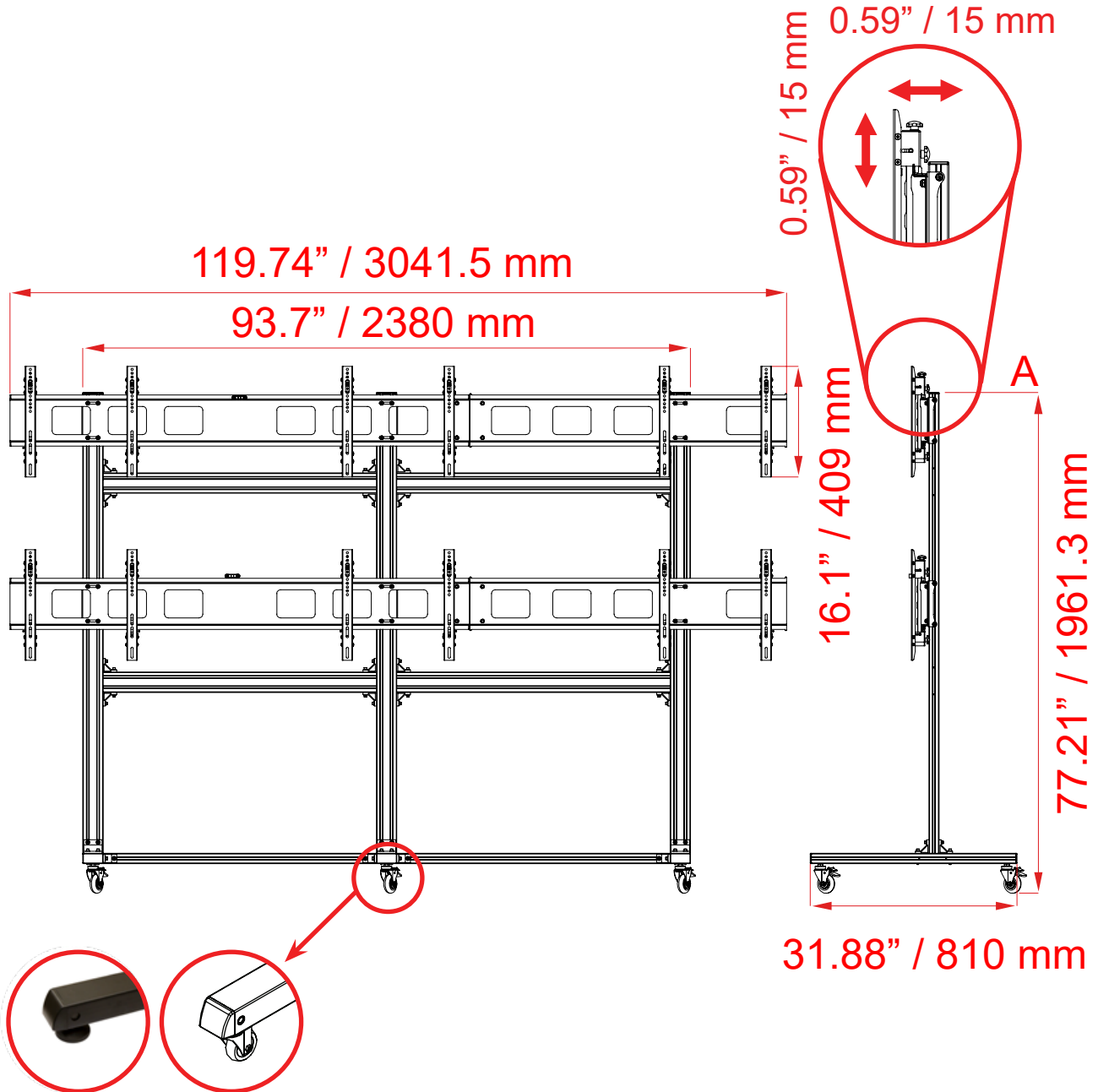

Caster or Stand

Contact ViewZ

- Address : 1030 N ARMANDO ST., ANAHEIM, CA 92806
- Phone : (714) 996-1177, Fax : (714) 996-1138
- Sales : sales@viewzusa.com