

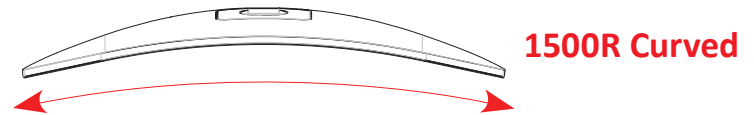

VZ-34CGM ADVANTAGES

- 34" Curved LED Panel
- Supports UWQHD (3440x1440) Resolution
- Ultrawide 1500R Curved Screen
- High Response Time - 1ms / Support MPRT
- Supported Display Port (1.2) In x2, HDMI (2.0) In x1, Audio Out x1
- Supports HDR 10
- Tilt 20° ~ -5°, Swivel ± 45°, Height Adjustment 4.48" (114 mm)
- Wide Viewing Angle (IPS Panel)



MODEL #		VZ-34CGM
VIDEO		
Screen Size	34"	
Max. Resolution	3440 x 1440 @60Hz	
Pixel Pitch	0.23175 mm x 0.23175 mm	
Brightness	400cd/m ² (Typical)	
Contrast Ratio	3000:1	
Aspect Ratio	21 : 9	
Viewing Angle (H/V)	178° / 178°	
Display Color	16.7 M	
Response Time	< 1 ms	
INTERFACE		
Display Port In	2	
HDMI (2.0) In	1	
USB	1	
Audio Out	1	
AUDIO		
Built in speaker	3W x 2	
SPECIAL FEATURES		
DDC/CI (Command)	Support	
MPRT (Moving Picture Response Time)	Support	
Advanced DCR (Dynamic Contrast Ratio)	Support	
Adaptive Sync	Support	
Blue Light Filter	Support	
HDR	Support	
PIP	Support	

DIMENSIONS & WEIGHT		
Outline Dimension (W x H x D)		31.78" x 14.24" x 4.5"
		807.4 mm x 361.81 mm x 114.37 mm
Net Weight / Gross Weight		17.85 lbs (8.09 kg) / 19.1 lbs (8.66 kg)
MOUNT		
VESA	100 x 100 mm (M4)	
GENERAL		
Power	Electrical Ratings Consumption	DC 12V (AC100 ~ 240V (50/60Hz)) / 5A ≤ 45 W
Regulations	CE, FCC (A), RoHS	
Operating Temperature	32 - 122°F / 0°C ~ 50°C	
Operating Humidity	20 ~ 85% RH	
Language (OSD)	English	
Compatible Mounts	Wall Ceiling	VZ-WM50, VZ-AM02-A VZ-CMKIT-01, VZ-CMKIT-02, VZ-CM308
Accessories	Stand (1set), Manual (1pc), Power Adapter (1pc), DP Cable (1pc)	

Contact ViewZ

- Address : 177 W. Orangethorpe Ave., Placentia, CA 92870
- Phone : (714) 996-1177, Fax : (714) 996-1138
- Sales : sales@viewzusa.com

DIMENSIONS

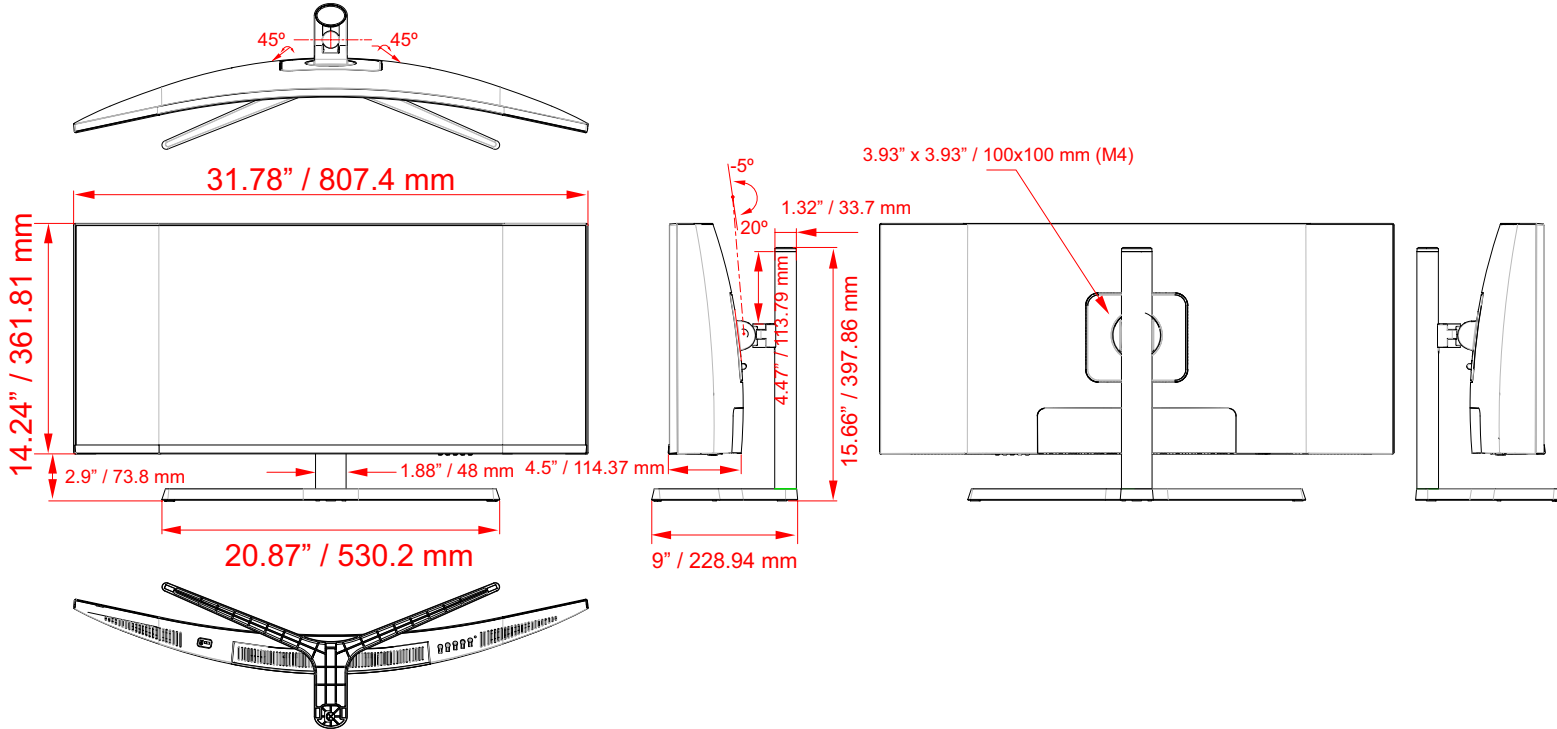

INTERFACE

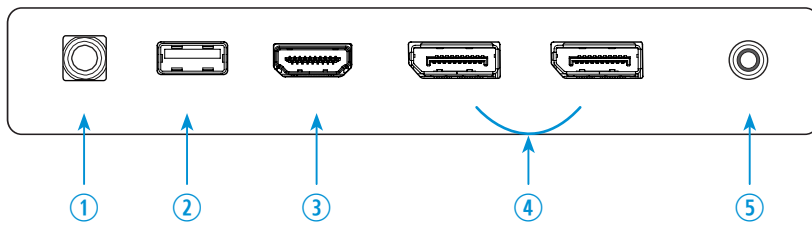

1. DC 12V
2. USB
3. HDMI IN
4. Display Port IN x2
5. Audio OUT

Contact ViewZ

- Address : 177 W. Orangethorpe Ave., Placentia, CA 92870
- Phone : (714) 996-1177, Fax : (714) 996-1138
- Sales : sales@viewzusa.com