

VZ-22CMP-ME

CLINICAL REVIEW HIGH-PERFORMANCE DISPLAY



MODEL #		VZ-22CMP-ME
SPECIFICATION		
Screen Size		21.5"
Max. Resolution		1920 x 1080 @60Hz
Pixel Pitch		0.24795 mm x 0.24795 mm
Brightness		250 cd/m ² (Typical)
Contrast Ratio		1000 : 1
Aspect Ratio		16 : 9
Viewing Angle (H/V)		178° / 178°
Display Color		16.7 Million
Response Time		< 8 ms
INTERFACE		
CVBS (BNC) In / Out		1 / 1
VGA In (15Pin D-Sub)		1
HDMI In		1
Audio In		1 / 1
AUDIO		
Built in Speaker		2W x 2
INTERFACE		
Filter Type		3D Comb-filter / De-Interlace
Language		English, Deutsch, French, Spanish, Italian
DIMENSIONS & WEIGHT		
Outline Dimension (W x H x D)		19.32" x 15.08" x 1.52" 490.9 mm x 383.1 mm x 38.8 mm
Net Weight / Gross Weight		4.62 lbs (2.1kg) / 6.61 lbs (3kg)
MOUNT		
VESA		75mm x 75mm (M4 x L8 screws)
GENERAL		
Power	Electrical Ratings	DC 12V, 3A (AC 100-240V, 50/60Hz)
	Consumption	≤ 22 W
Warranty		3 Year
Operating Temperature Humidity		14 ~ 122°F / -10 ~ 50°C 5 ~ 90% RH
Regulations		FCC(A), CE, RoHS
Compatible Mounts	Wall	VZ-WM05, VZ-WM11, VZ-AM02-A
	Ceiling	VZ-CMKIT-01, VZ-CM308
	Rack	VZ-RMK08

VZ-22CMP-ME ADVANTAGES

- 21.5" Full HD Resolution
- 3D Comb-filter, De-Interlace
- 16:9 / 4:3 Ratio Available, HDMI, VGA, PC Audio, AV Audio
- 1 CVBS (BNC) Input / Output (Loop-through)
- Built-in Speakers, Auto Source & Power Recovery
- Medical Safety Power Supply Approved (2 x MOPP) according to ANSI/AAMI ES60601-1 and IEC/EN60601-1
- Built to run 24/7/365
- 3-Year Warranty

DIMENSIONS

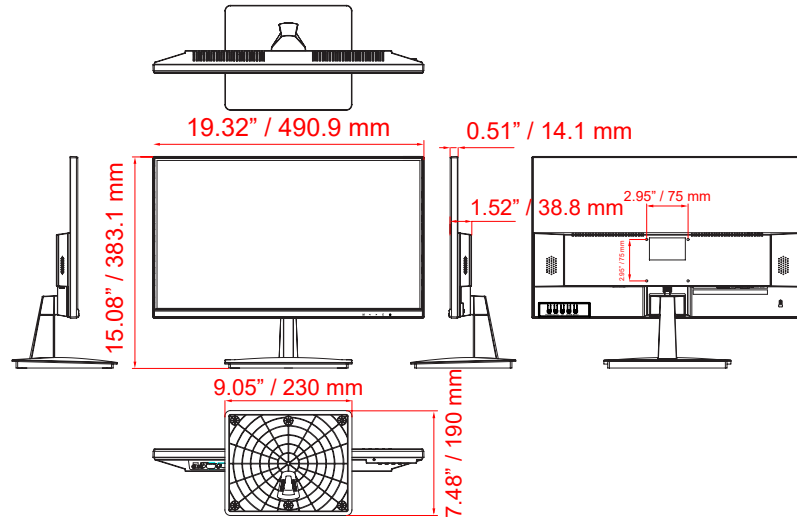

INTERFACE

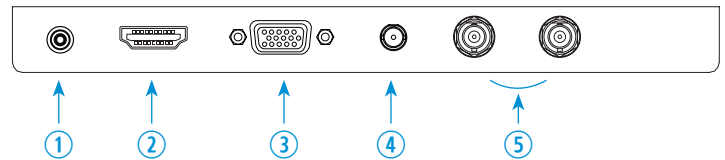

1. DC12V IN
2. HDMI IN
3. VGA IN
4. Audio IN
5. CVBS (BNC) IN / OUT

Contact ViewZ

- Address : 177 W. Orangethorpe Ave., Placentia, CA 92870
- Phone : (714) 996-1177, Fax : (714) 996-1138
- Sales : sales@viewzusa.com