

# VZ-17RTN-ME

## CLINICAL REVIEW HIGH-PERFORMANCE DISPLAY



MODEL #		VZ-17RTN-ME
<b>SPECIFICATION</b>		
Screen Size		17"
Max. Resolution		1280 x 1024 @60Hz
Pixel Pitch		0.264 mm x 0.264 mm
Brightness		300 cd/m <sup>2</sup> (Typical)
Contrast Ratio		700 : 1
Aspect Ratio		5 : 4
Viewing Angle (H/V)		170° / 160°
Display Color		16.7 Million
Response Time		< 5 ms
<b>INTERFACE</b>		
AV (Composite) In / Out		1 / 1
VGA In (15Pin D-Sub)		1
HDMI In		1
Audio In / Out		1 / 1
<b>AUDIO</b>		
Built in Speaker		1.5 W x 2
<b>INTERFACE</b>		
Filter Type		3D Comb-filter / De-Interlace
Language		English, Deutsch, French, Spanish, Italian
<b>DIMENSIONS &amp; WEIGHT</b>		
Outline Dimension (W x H x D)		15.06" x 12.40" x 1.78" 382.60 x 315.10 x 45.30 mm
Net Weight / Gross Weight		6.10 lbs ( 2.77 kg ) / 7.20 lbs ( 3.27 kg )
<b>MOUNT</b>		
VESA		75mm x 75mm ( M4 x L8 screws )
<b>GENERAL</b>		
Power	Electrical Ratings Consumption	DC 12V, 3A (AC 100-240V, 50/60Hz) ≤ 20 W
Warranty		3 Year
Operating Temperature   Humidity		14 ~ 122°F / -10 ~ 50°C   20 ~ 70% RH
Regulations		FCC(A), CE, RoHS
Compatible Mounts	Wall Ceiling Rack	VZ-WM05, VZ-WM11, VZ-AM02-A VZ-CMKIT-01, VZ-CM308 VZ-RMK08

## VZ-17RTN-ME ADVANTAGES

- 17" LED CCTV Monitor
- 3D Comb-filter, De-Interlace, 600 TV Line
- HDMI, VGA
- 2 BNC(Composite) Inputs / 1 BNC (Composite) Output (Loop-through)
- Built-in Speakers, Auto Source & Power Recovery
- Medical Safety Power Supply Approved (2 x MOPP)  
according to ANSI/AAMI ES60601-1 and IEC/EN60601-1
- Built to run 24/7/365
- 3-Year Warranty

## DIMENSIONS

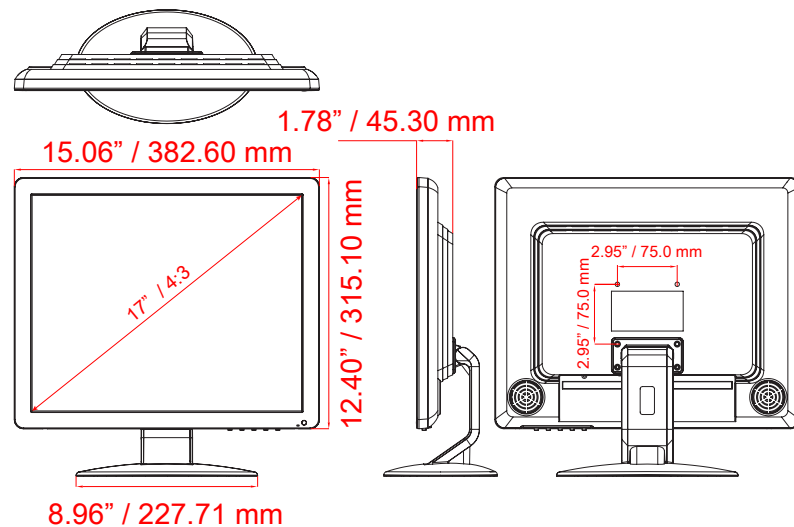

## INTERFACE

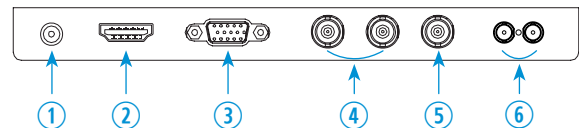

1. DC12V IN
2. HDMI IN
3. VGA IN
4. AV 1, AV 2 IN
5. AV OUT
6. AUDIO IN / OUT

## Contact ViewZ

- Address : 177 W. Orangethorpe Ave., Placentia, CA 92870
- Phone : (714) 996-1177, Fax : (714) 996-1138
- Sales : sales@viewzusa.com