

VZ-101RTC

PREMIUM LED CCTV MONITOR



VZ-101RTC ADVANTAGES

- 10.1" LED CCTV Monitor
- 16:9 / 4:3 mode Available
- BNC, HDMI, VGA, TRIGGER
- 2D Comb-filter, Noise Reduction, Built-in Speakers
- Built to run 24/7/365
- 3-Year Warranty



MODEL # VZ-101RTC	
VIDEO	
Screen Size	10.1"
Max. Resolution	1024 x 600 @60Hz
Pixel Pitch	0.2175 mm x 0.2088 mm
Brightness	300cd/m ² (Typical)
Contrast Ratio	800:1
Aspect Ratio	16 : 9
Viewing Angle (H/V)	170° / 170°
Display Color	16.7 Million
Response Time	< 25 ms
AUDIO	
Built in speaker	1W x 2
INTERFACE	
AV (Composite) In/ BNC Out	2 / 1
HDMI In	1
RGB In(15Pin D-Sub)	1
Trigger In	1
Audio In	1
SPECIAL FEATURES	
Filter Type	2D Comb-filter / Noise Reduction
Multi-lingual Language	English, Spanish, French, German, Italian, Portuguese, Polish, Russian

DIMENSIONS & WEIGHT		
Outline Dimension (W x H x D)	Without Stand	9.92 x 7.28 x 1.05" (252.0 x 185.0 x 26.80 mm)
	With Stand	43.07 x 26.25 x 7.08" / 1094.2 x 666.8 x 180.0 mm
Net Weight	2.86 lbs / 1.3 Kg	
Gross Weight	3.52 lbs / 1.6Kg	
MOUNT		
VESA	75mm x 75mm, M4 x L8 Screws	
GENERAL		
Transmitter - IR Remote Control	YES	
Power	Electrical Ratings	DC 12V, 2.0 A (AC100 ~ 240V[50/60Hz])
	Consumption	≤ 8W
Operating Temperature	14 ~ 122°F / -10°C ~ 50°C	
Operating Humidity	20 ~ 70% RH	
Warranty (Parts/ Labor)	3 Year / 3 Year	
Regulations	CE, FCC(A), NDA A	
Compatible Mounts	Wall	VZ-WM05, VZ-WM11
	Pole	VZ-SM01, VZ-SCM, VZ-SCM-S, VZ-SCM-SQ
	Ceiling	VZ-RMK08

Contact ViewZ

- Address : 1030 N ARMANDO ST., ANAHEIM, CA 92806
- Phone : (714) 996-1177, Fax : (714) 996-1138
- Sales : sales@viewzusa.com

VZ-101RTC

PREMIUM LED CCTV MONITOR

DIMENSION

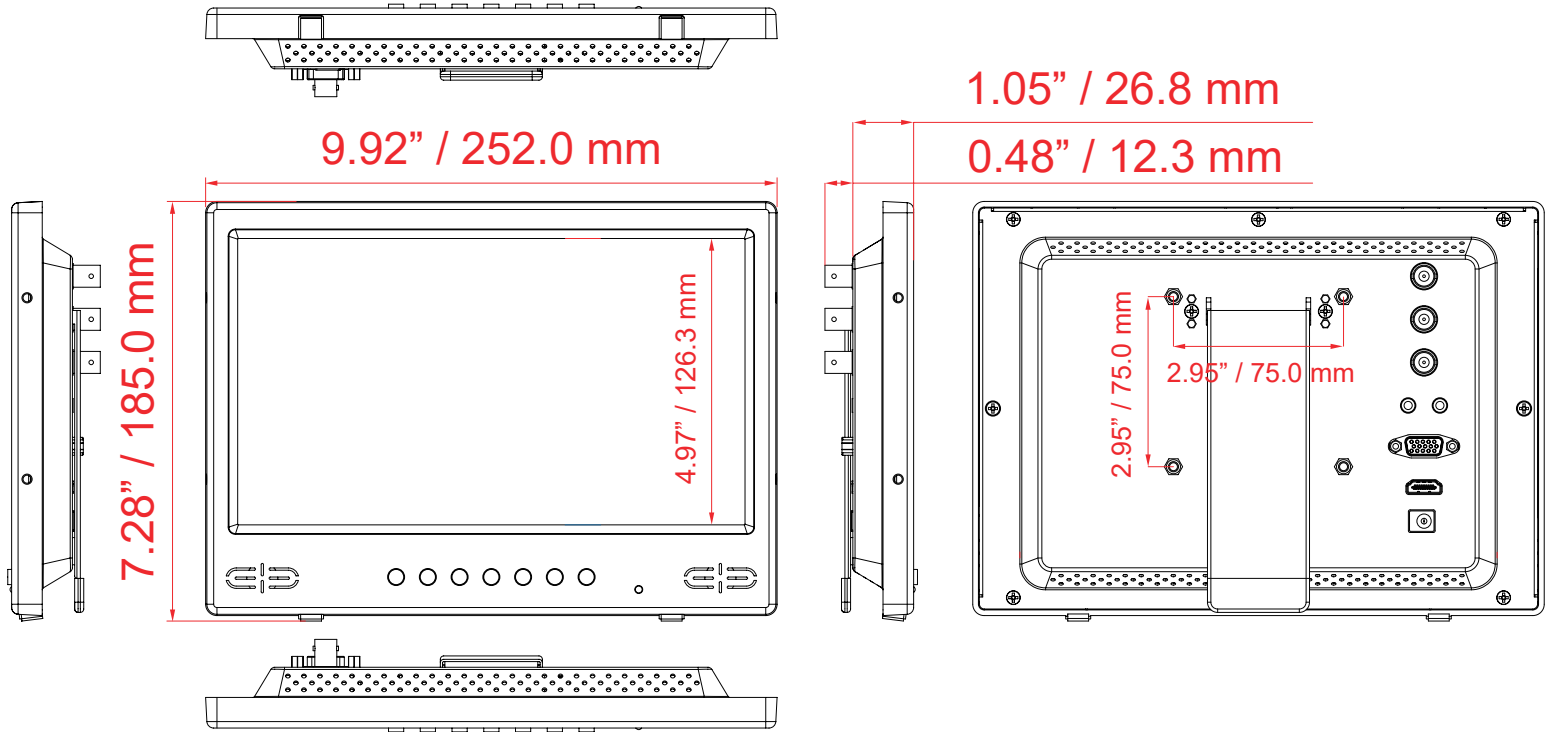

INTERFACE

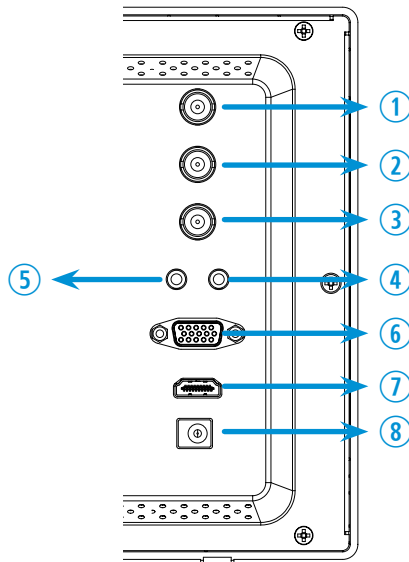

1. BNC (Composite) OUT
2. BNC (Composite) IN #1
3. BNC (Composite) IN #2
4. Audio IN
5. Trigger IN
6. VGA IN
7. HDMI IN
8. DC 12V IN

Contact ViewZ

- Address : 1030 N ARMANDO ST., ANAHEIM, CA 92806
- Phone : (714) 996-1177, Fax : (714) 996-1138
- Sales : sales@viewzusa.com