

# VZ-RMK08

ViewZ Rack Mount Bracket for **Single or Dual Monitors**

---

## VZ-RMK08 INSTALLATION INSTRUCTIONS

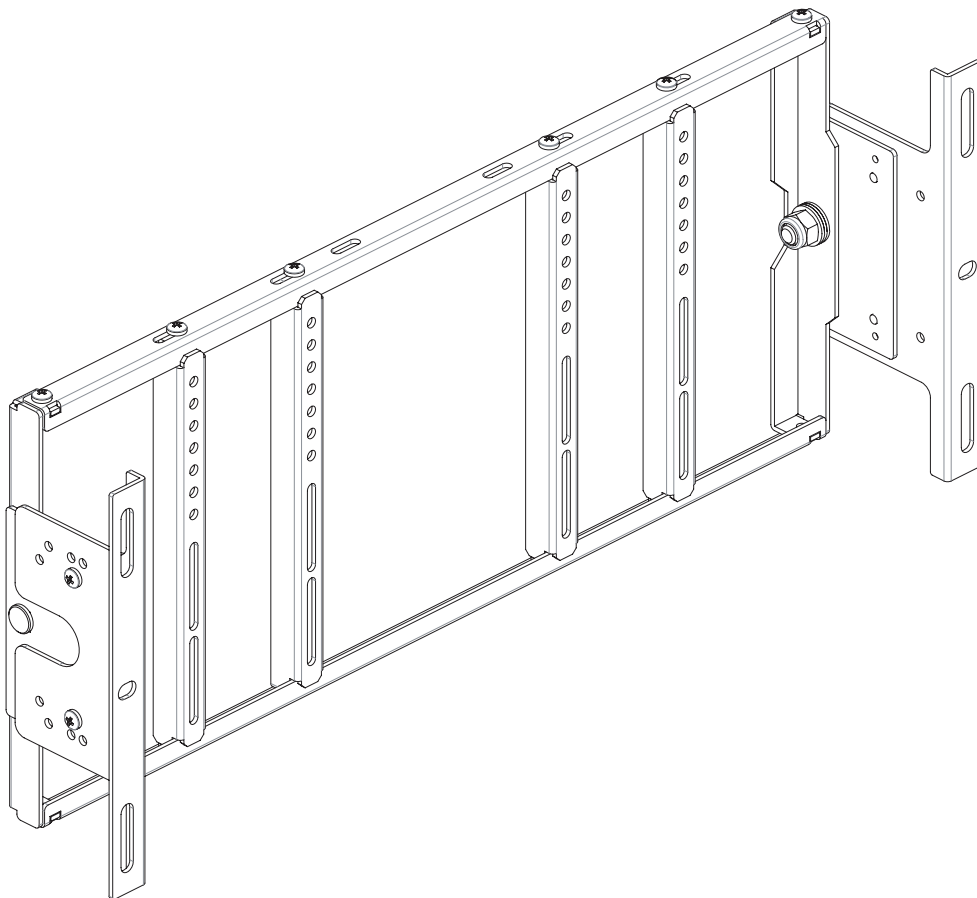

**ViewZ**<sup>®</sup>  
[www.viewzusa.com](http://www.viewzusa.com)

## Contents

Weight Limit .....	2
Warning Statements .....	2
Installation Tools .....	3
Parts List .....	3
Installing the Mount .....	5
Dimension & Technical Specifications .....	8
Warranty .....	10

## Weight Limit

Maximum Flat-panel Weight: **21.4 lbs**

THE WALL STRUCTURE MUST BE CAPABLE OF SUPPORTING AT LEAST FIVE TIMES THE WEIGHT OF THE FLAT-PANEL. IF NOT, THE WALL STRUCTURE MUST BE REINFORCED.

## Warning Statements

 PRIOR TO THE INSTALLATION OF THIS PRODUCT, THE INSTALLATION INSTRUCTIONS MUST BE READ AND COMPLETELY UNDERSTOOD. KEEP THESE INSTALLATION INSTRUCTIONS IN AN EASILY ACCESSIBLE LOCATION FOR FUTURE REFERENCE.

 PROPER INSTALLATION PROCEDURE BY A QUALIFIED SERVICE TECHNICIAN MUST BE FOLLOWED, AS OUTLINED IN THESE INSTALLATION INSTRUCTIONS. FAILURE TO DO SO COULD RESULT IN PROPERTY DAMAGE, SERIOUS PERSONAL INJURY, OR EVEN DEATH.

 SAFETY MEASURES MUST BE PRACTICED AT ALL TIMES DURING THE ASSEMBLY OF THIS PRODUCT. USE PROPER SAFETY EQUIPMENT AND TOOLS FOR THE ASSEMBLY PROCEDURE TO PREVENT PERSONAL INJURY.

 ViewZ USA DOES NOT WARRANT AGAINST DAMAGE CAUSED BY THE USE OF ANY ViewZ USA PRODUCT FOR PURPOSES OTHER THAN THOSE FOR WHICH IT WAS DESIGNED OR DAMAGE CAUSED BY UNAUTHORIZED ATTACHMENTS OR MODIFICATIONS, AND IS NOT RESPONSIBLE FOR ANY DAMAGES, CLAIMS, DEMANDS, SUITS, ACTIONS OR CAUSES OF ACTION OF WHATEVER KIND RESULTING FROM, ARISING OUT OF OR IN ANY MANNER RELATING TO ANY SUCH USE, ATTACHMENTS OR MODIFICATIONS.

 At least two qualified people should perform the assembly procedure. Personal injury and/or property damage can result from dropping or mishandling the flat-panel.

 If mounting to wall studs or ceiling studs, make sure that the mounting screws are anchored into the center of the wall studs or ceiling studs. Use of an edge-to-edge stud finder is recommended.

 It is recommended that a maximum of 3/8" plaster board be used when mounting to wooden studs.

 Be aware of the mounting environment. If drilling and/or cutting into the mounting surface, always make sure that there are no electrical wires in wall. Cutting or drilling into an electrical line may cause serious personal injury.

 Make sure there are no water or natural gas lines inside the wall where the mount is to be located. Cutting or drilling into a water or gas line may cause severe property damage or personal injury.







 This product is intended for indoor use only. Use of this product outdoors could lead to product failure and/or serious personal injury.

 Do not install near sources of high heat. Do not install on a structure that is prone to vibration, movement or chance of impact.

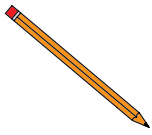
 Contact ViewZ with any questions:  
(888) 998-4399  
techsupport@viewzusa.com

## Installation Tools

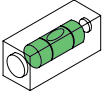
The following tools may be required depending on your installation.

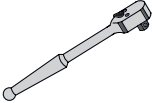
				
Electronic Stud Finder	Pencil	Protective Eye-wear	Portable Drill	Phillips Head Screw Drill
				
Level	1/2" Socket	Phillips Head Screwdriver	Socket Wrench	

## RMK RACK Mount Assembly Components - provided

Your ViewZ mount product is shipped with all proper installation hardware and components. If there are parts missing and/or damaged, please stop the installation and contact ViewZ USA at (888)-998-4399.

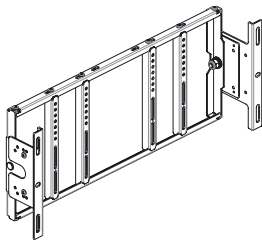
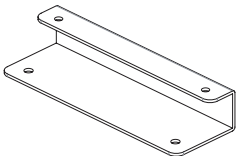
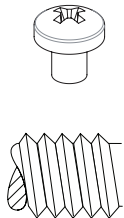
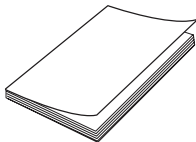
			
Rack Mount Bracket (Qty 1)	20" Guide Bracket (Qty 2) - Over 20 inch	M4 x L8 Screws (Qty 16)	User Manual (Qty 1)

## General Installation

Attach a single monitor (or dual small monitors) to the Rack Mount Bracket from the back side using the VESA 75mm or 100mm mounting holes and M4x8 Machine screws.

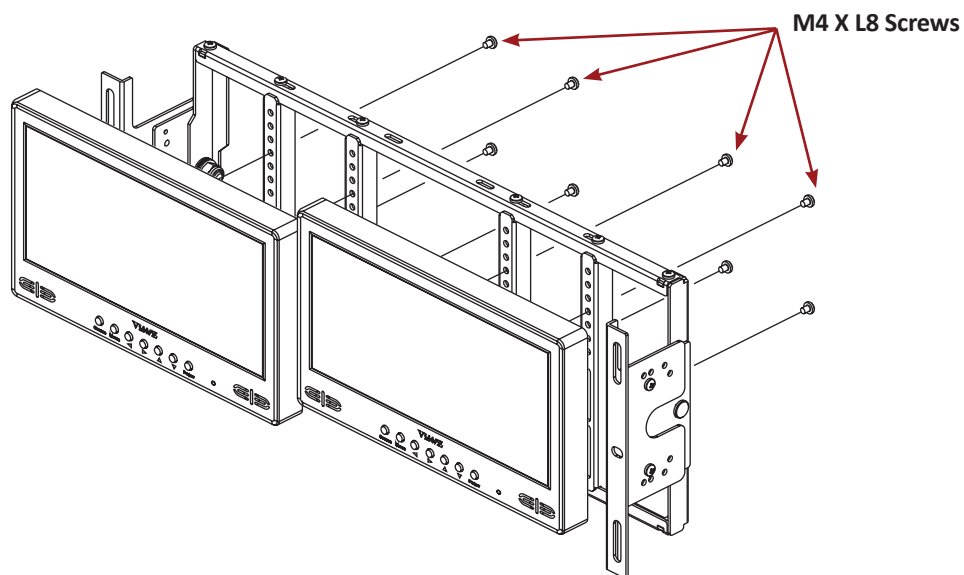
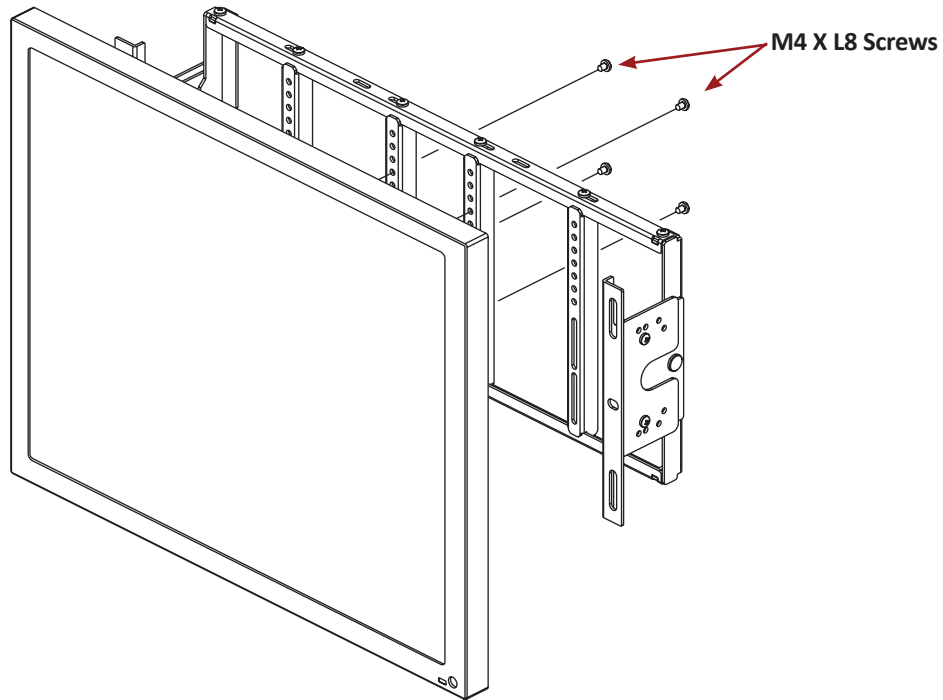

### WARNING !

If user uses screws longer than M4 x L8 mm, it may cause damage to the unit. Please use bolt of correct size and length as instructed.



### Mounting Safety !

At least two people are recommended to safely install the mount.

## 20" Guide Bracket Installation

Use 20" guide brackets for 20 inch or bigger monitors

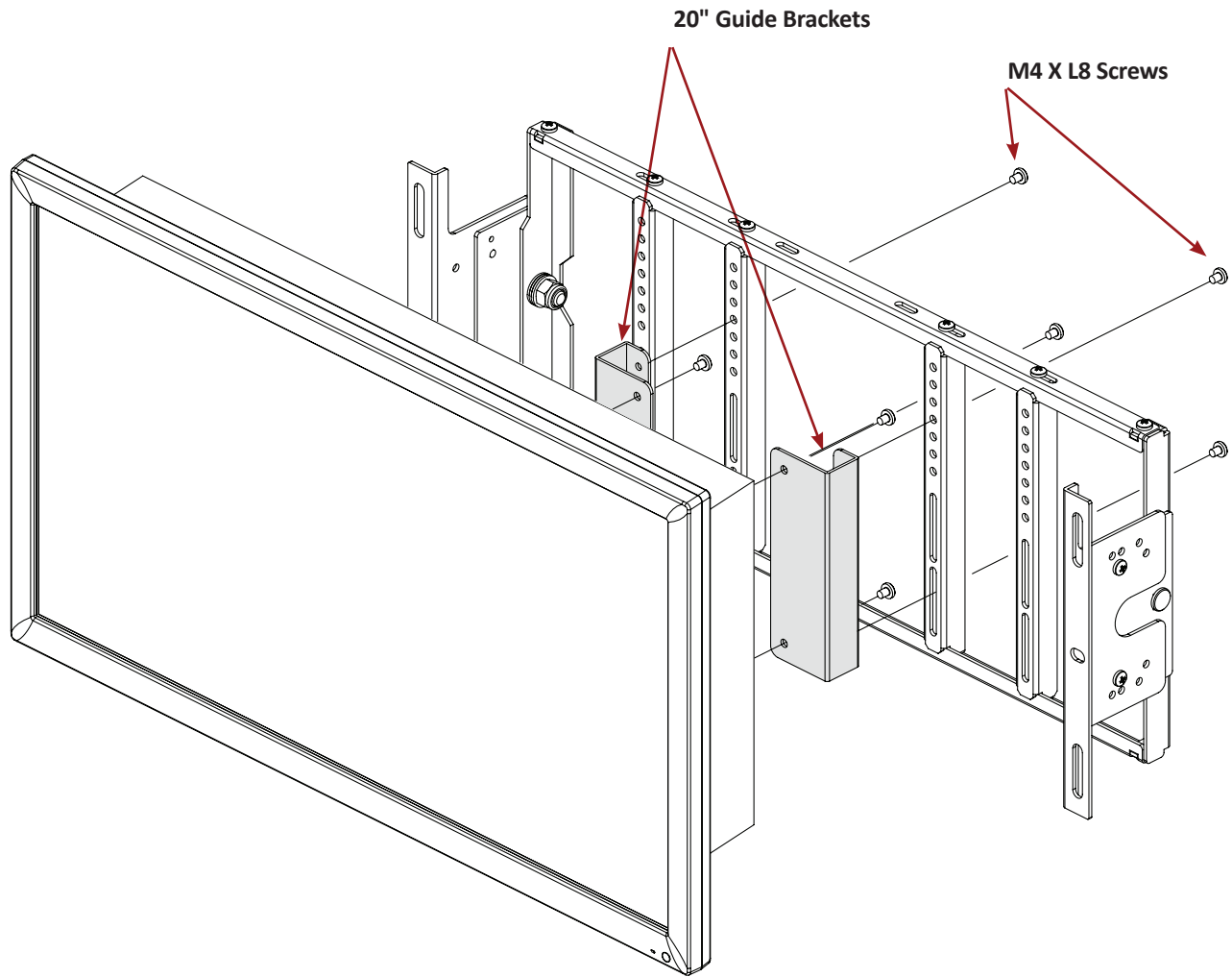

## Rack Bracket Installation

Use two **rack brackets** as shown below picture, attach each **rack bracket** to the **monitor mount bracket** using by M4 x L8 screws.

Based on the depth of monitor, user need to find proper holes to hold mointor.

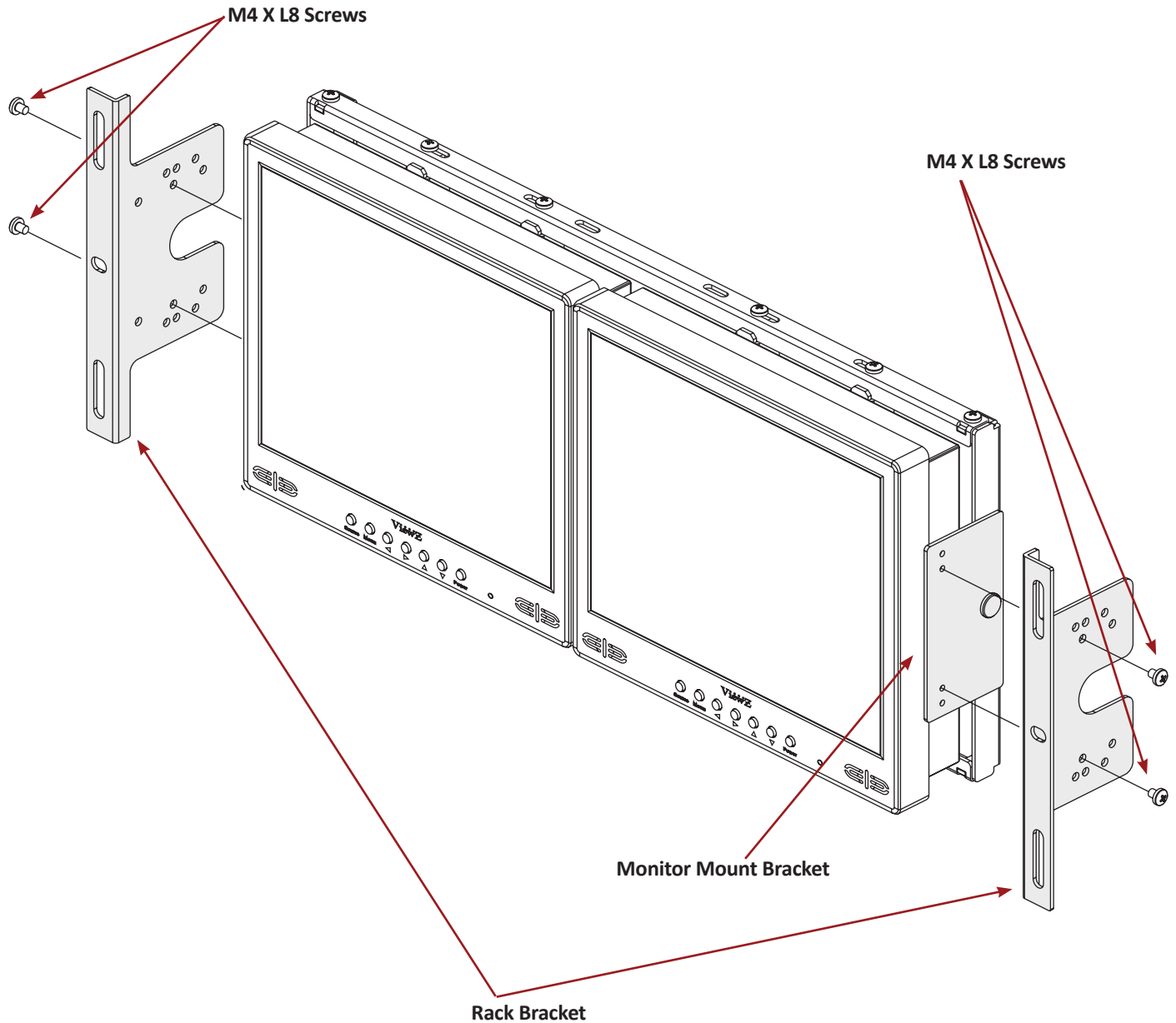

### WARNING !

The depth of the monitor in the rack is controlled by the side brackets.

## Rack Mount Installation

Carefully hold the assembled rack mount with monitor or monitors to the cabinet and install using four or more screws (not included) based on rack cabinet type.

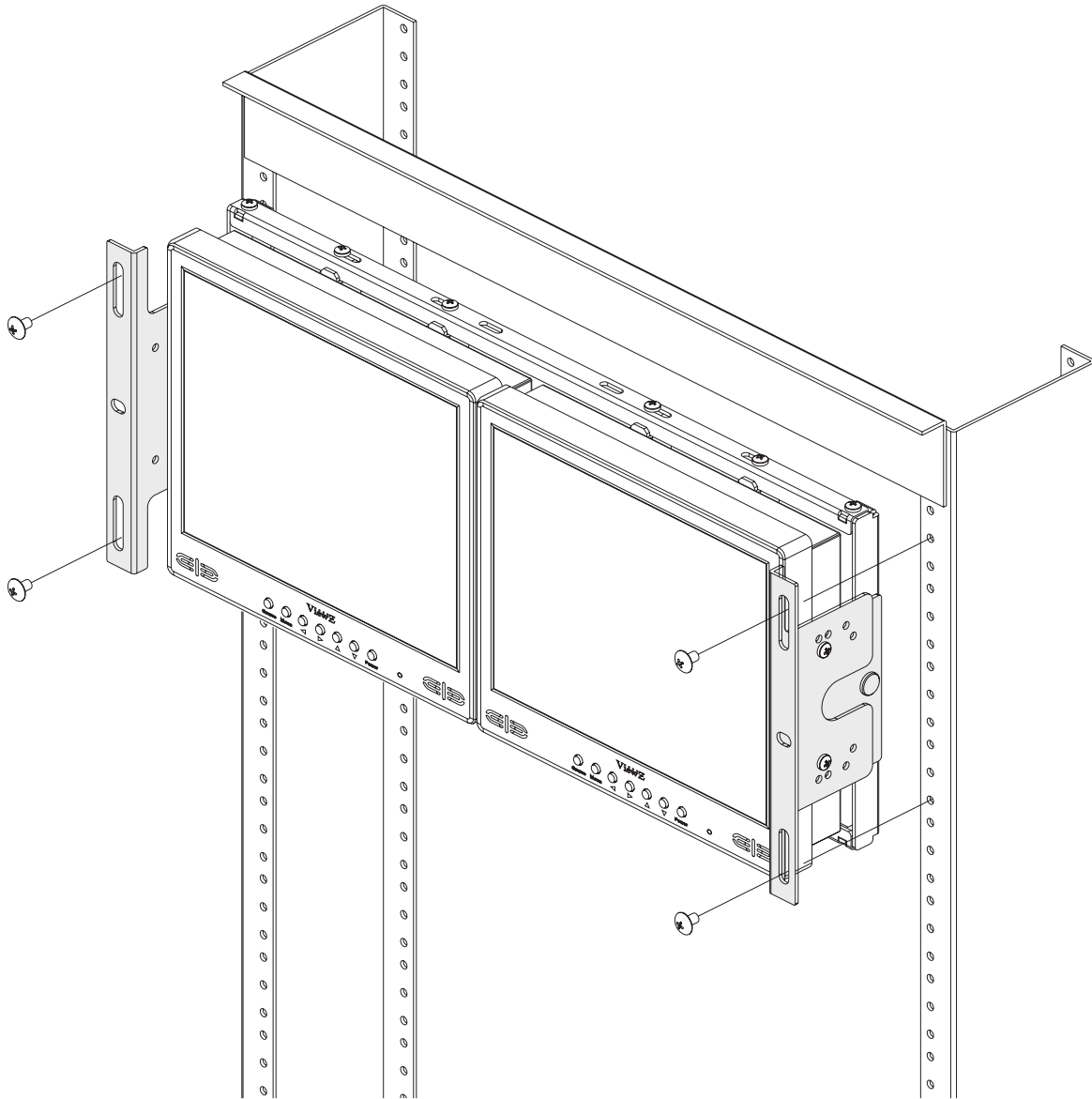

## Dimension &amp; Specification

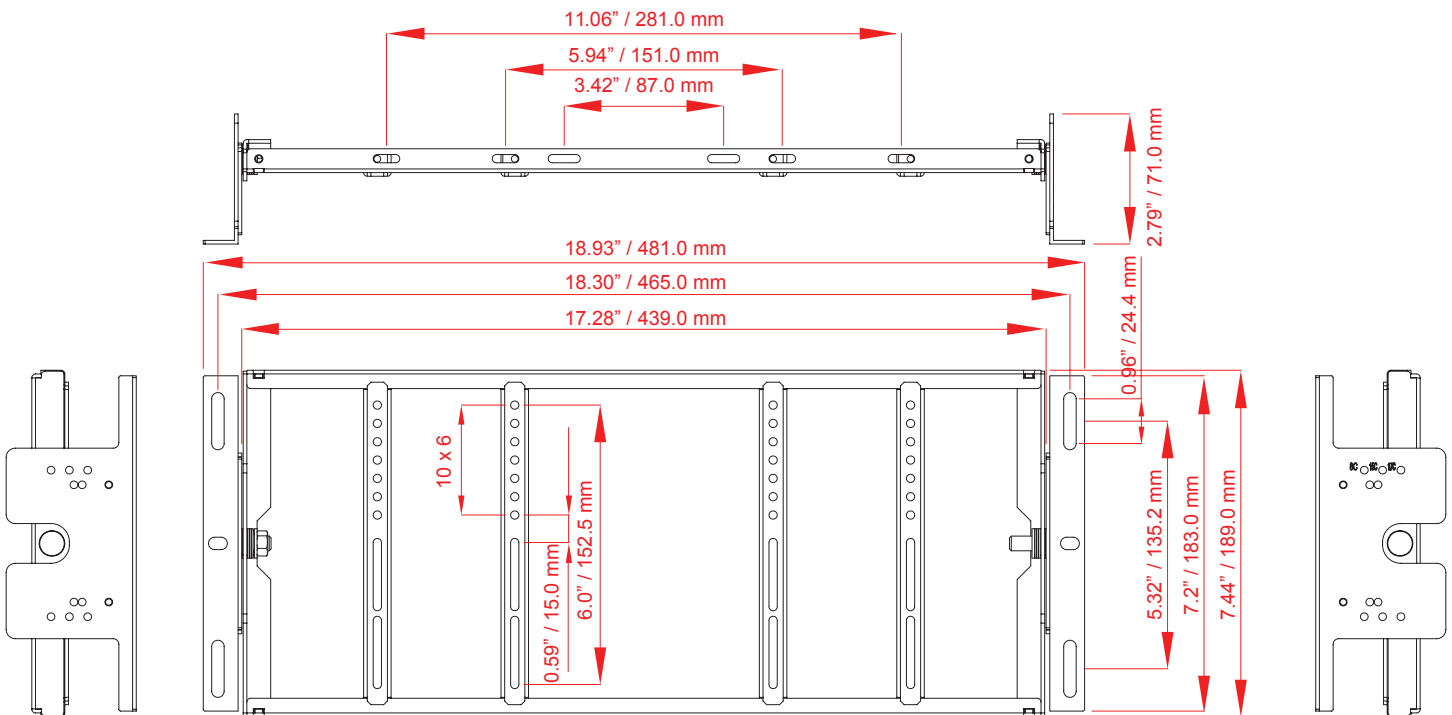

Model No.	VZ-RMK08
Display Range	Dual 8"/9", Single 8 ~ 24"
Depth Adjustment Range	1.45" ~ 3.14" / 37 ~ 80 mm
Weight Capacity	20.94 lbs / 9.5 kg
Tilt Capability	+35° ~ -35°
Net Weight	3.08 lbs / 1.4 kg
Gross Weight	5.07 lbs / 2.3 kg
Dimension ( Width x Height x Depth )	18.93 x 7.44 x 2.79" / 481 x 189 x 71mm
DIM Size ( Width x Height x Depth )	17.28 x 7.2 x 1.81" / 439 x 183 x 46mm
Box Dimension( Width x Height x Depth )	20.27 x 8.66 x 3.54" / 515 x 220 x 90mm
Mounting Patterns Type	VESA, Universal
Mounting Patterns (VESA)	75 x 75 (Min) ~ 100 x 100 (Max) mm
Accessories	Rack Mount Bracket (1 set), 20" Guide Bracket (1 set), M4 x L8 Screws (10 pcs), User Manual





## Warranty

### ViewZ USA LIMITED LIFETIME WARRANTY

#### What and Who is Covered by this Limited Warranty and for How Long

ViewZ USA warrants this product to be free from defects in material and workmanship for the lifetime of the original owner of this product. The limited warranty is valid only for the original purchaser of the product.

#### What ViewZ USA Will Do

At the sole option of ViewZ USA, ViewZ USA will repair or replace any product or product part that is defective. If ViewZ USA chooses to replace a defective product or part, a replacement product or part will be shipped to you at no charge, but you must pay any labor costs.

#### What is Not Covered; Limitations

ViewZ USA DISCLAIMS ANY LIABILITY FOR DAMAGE TO MOUNTS, ADAPTERS, DISPLAYS, PROJECTORS, OTHER PROPERTY, OR PERSONAL INJURY RESULTING, IN WHOLE OR IN PART, FROM IMPROPER INSTALLATION, MODIFICATION, USE OR MISUSE OF ITS PRODUCTS.

ViewZ USA DISCLAIMS ALL OTHER WARRANTIES, EXPRESS OR IMPLIED, INCLUDING WARRANTIES OF MERCHANTABILITY AND FITNESS FOR A PARTICULAR PURPOSE. ViewZ USA IS NOT RESPONSIBLE FOR INCIDENTAL OR CONSEQUENTIAL DAMAGES, INCLUDING BUT NOT LIMITED TO, INABILITY TO USE ITS PRODUCTS OR LABOR COSTS FOR REMOVING AND REPLACING DEFECTIVE PRODUCTS OR PARTS. SOME STATES DO NOT ALLOW THE EXCLUSION OR LIMITATION OF INCIDENTAL OR CONSEQUENTIAL DAMAGES, SO THE ABOVE LIMITATION OR EXCLUSION MAY NOT APPLY TO YOU.

#### What Customers Must Do for Limited Warranty Service

If you discover a problem that you think may be covered by the warranty you MUST REPORT it in writing to the address below within thirty (30) days. Proof of purchase (an original sales receipt) from the original consumer purchaser must accompany all warranty claims. Warranty claims must also include a description of the problem, the purchaser's name, address, and telephone number. General inquiries can be addressed to ViewZ USA Customer Service at 1-888-998-4399. Warranty claims will not be accepted over the phone or by fax.

ViewZ USA  
Attn: Warranty Claim  
177 W. Orangethorpe Ave.  
Placentia, CA 92870

#### How State Law Applies

THIS WARRANTY GIVES YOU SPECIFIC LEGAL RIGHTS, AND YOU MAY ALSO HAVE OTHER RIGHTS WHICH VARY FROM STATE TO STATE.

## Disclaimer

ViewZ USA intends to make this manual accurate and complete. However, ViewZ USA makes no claim that the information contained herein covers all details, conditions or variations, nor does it provide for every possible contingency in connection with the installation or use of this product. The information contained in this document is subject to change without notice or obligation of any kind. ViewZ USA makes no representation of warranty, expressed or implied, regarding the information contained herein. ViewZ USA assumes no responsibility for accuracy, completeness or sufficiency of the information contained in this document.

## Contact Us

#### NORTH AMERICA

177 W. Orangethorpe Ave.

Placentia, CA 92870

USA and Canada

Phone: 1-888-998-4399

Fax: 1-714-996-1138

Other Locations

Phone: (001) 888-998-4399

Fax: (001) 714-996-1138

© ViewZ USA