

VZ-DC24-320

ViewZ DC-24-30 Power Supply

VZ-DC24-320 Field Wiring and Mounting Instructions



ViewZ[®]
www.viewzusa.com

Contents

Installation Tools	3
Warning Statements	3
Mounting	4
Wiring	5
Warranty	6

Field Wiring and Mounting Instructions

The following tools may be required depending on your installation.

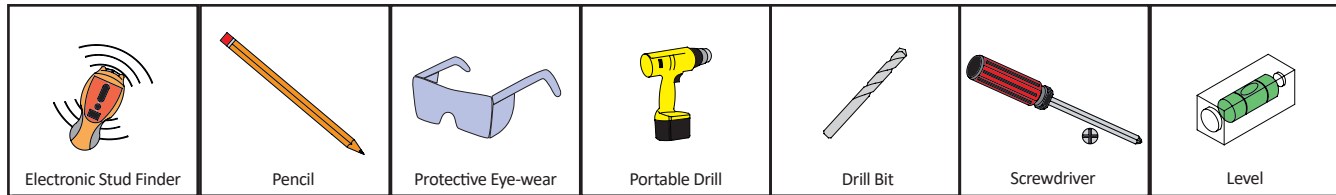

UL Installation Requirements

Minimum screw size - 2 1/4" length, 0.117" (11/64) thread diameter, 0.4" head diameter
Wire - 14AWG ~ 18 AWG with temperature tolerance of 105c

Warning Statements

 PRIOR TO THE INSTALLATION OF THIS PRODUCT, THE INSTALLATION INSTRUCTIONS MUST BE READ AND COMPLETELY UNDERSTOOD. KEEP THESE INSTALLATION INSTRUCTIONS IN AN EASILY ACCESSIBLE LOCATION FOR FUTURE REFERENCE.

 It is recommended that a maximum of 5/8" plaster board be used when mounting to wooden studs.

 Be aware of the mounting environment. If drilling and/or cutting into the mounting surface, always make sure that there are no electrical wires in wall. Cutting or drilling into an electrical line may cause serious personal injury.

 Make sure there are no water or natural gas lines inside the wall where the mount is to be located. Cutting or drilling into a water or gas line may cause severe property damage or personal injury.

 Wiring and Mounting of Power Supply must be done by a trained and authorized service technician.

 Power Supply should be mounted on wall with a flat service in an area designated for authorized personnel only.

 Do not apply power to unit until mounting and all connections are made.

 Do not install near water, high moisture, open flames or sources of high levels of heat.

 Power output cabling must be housed within a cable tray, conduit, or plenum area for continuous protection to the cabling.

 Only use copper wire for output cabling. The type of wire and its rated Ampacity are determined using NEC ANSI/NFPA 70 Article 310.

 The wire's rated Ampacity for output cabling must be derated by multiplying by 0.8 as specified in ANSI/NFPA Article 645.5A.

 Always crimp a UL listed ring terminal to each wire according to the ring terminal manufacturer's instructions.

 It is recommended that a maximum of 5/8" plaster board be used when mounting to wooden studs.

 Contact ViewZ with any questions:
(888) 998-4399
techsupport@viewzusa.com

Mounting

Use #12 Screws or Bolts that are at least 1.25" in length

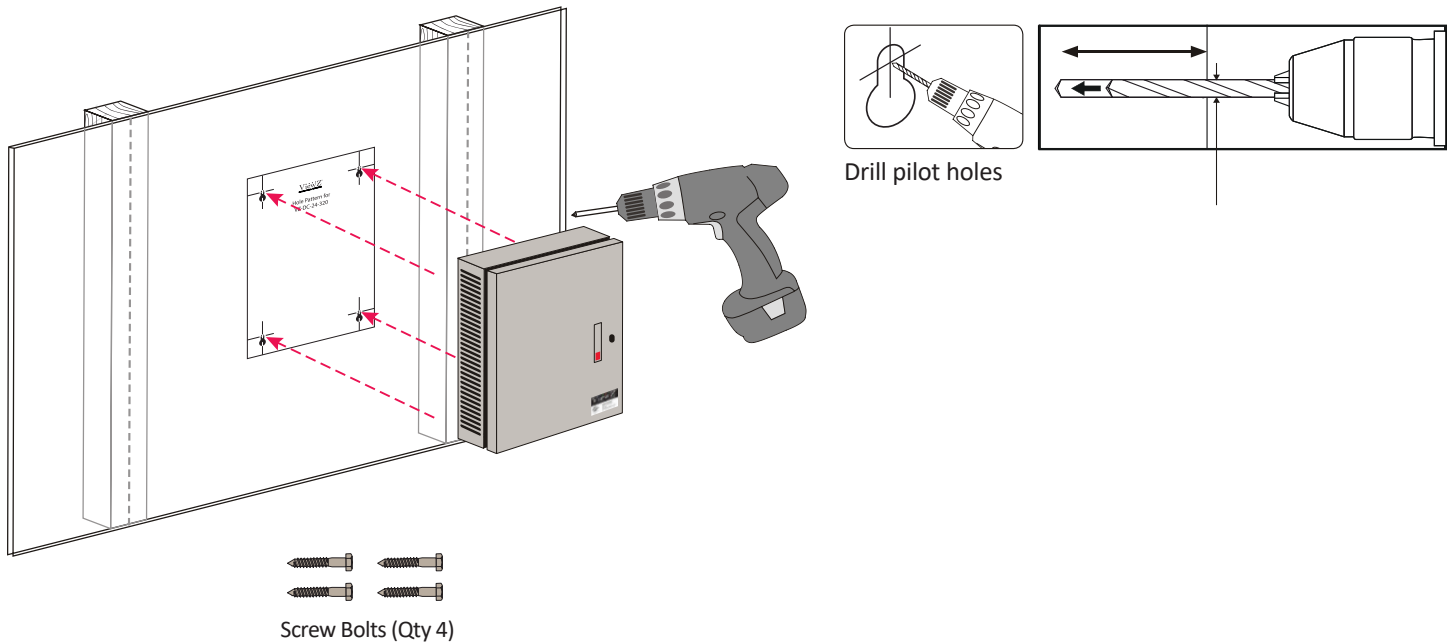

1. Use the hole pattern provided to mark where the mounting screws will be located.
2. Drill in mounting screws $\frac{1}{4}$ " away from wall. (Pilot holes might be needed).
3. If not drilling to a stud, use proper fastener/support (e.g. drywall anchor).
4. Place the Power Supply Box Keyholes over the mounting screws.
5. Secure the Power Supply by tightening screws.

 If mounting to wall studs or ceiling studs, make sure that the mounting screws are anchored into the center of the wall studs or ceiling studs. Use of an edge-to-edge stud finder is recommended.

Wiring

*Use 18AWG Copper Wire or larger for output power

Diagram of Power Supply Connections

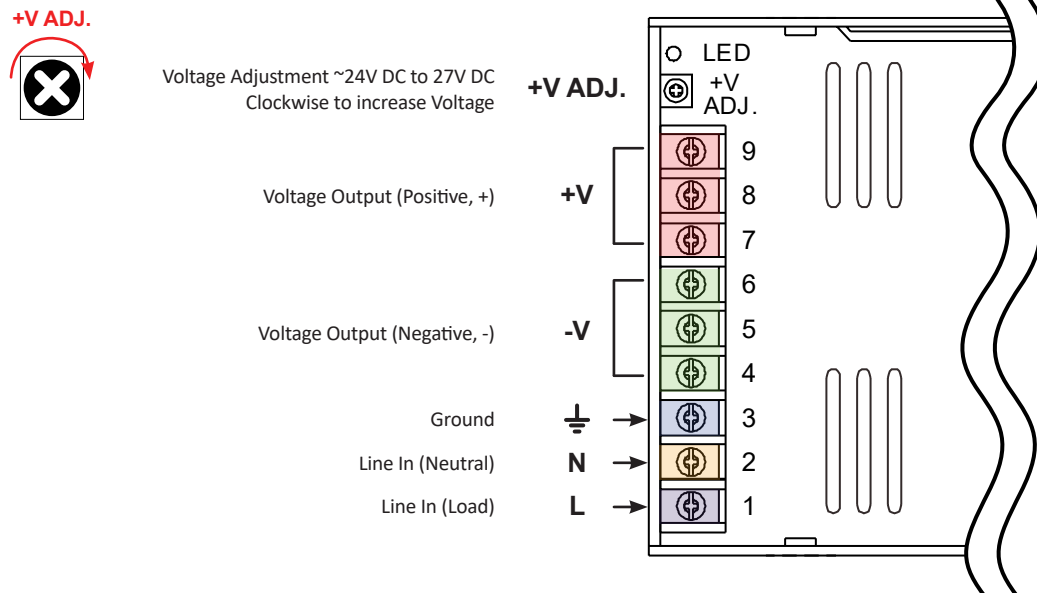

1. Connect wires from monitor to the terminal blocks (V+) and (V-) using a Phillips screwdriver. To avoid damaging the monitor, use correct polarity.
2. Once unit is powered, the amount of output voltage can be adjusted (+V ADJ), if needed for longer cable runs that have resulted in a voltage drop.

Warranty

ViewZ USA LIMITED 2 YEAR WARRANTY

What and Who is Covered by this Limited Warranty and for How Long

ViewZ USA warrants this product to be free from defects in material and workmanship for 2 YEAR of the original owner of this product. The limited warranty is valid only for the original purchaser of the product.

What ViewZ USA Will Do

At the sole option of ViewZ USA, ViewZ USA will repair or replace any product or product part that is defective. If ViewZ USA chooses to replace a defective product or part, a replacement product or part will be shipped to you at no charge, but you must pay any labor costs.

What is Not Covered; Limitations

ViewZ USA DISCLAIMS ANY LIABILITY FOR DAMAGE TO MOUNTS, ADAPTERS, DISPLAYS, PROJECTORS, OTHER PROPERTY, OR PERSONAL INJURY RESULTING, IN WHOLE OR IN PART, FROM IMPROPER INSTALLATION, MODIFICATION, USE OR MISUSE OF ITS PRODUCTS.

ViewZ USA DISCLAIMS ALL OTHER WARRANTIES, EXPRESS OR IMPLIED, INCLUDING WARRANTIES OF MERCHANTABILITY AND FITNESS FOR A PARTICULAR PURPOSE. ViewZ USA IS NOT RESPONSIBLE FOR INCIDENTAL OR CONSEQUENTIAL DAMAGES, INCLUDING BUT NOT LIMITED TO, INABILITY TO USE ITS PRODUCTS OR LABOR COSTS FOR REMOVING AND REPLACING DEFECTIVE PRODUCTS OR PARTS. SOME STATES DO NOT ALLOW THE EXCLUSION OR LIMITATION OF INCIDENTAL OR CONSEQUENTIAL DAMAGES, SO THE ABOVE LIMITATION OR EXCLUSION MAY NOT APPLY TO YOU.

What Customers Must Do for Limited Warranty Service

If you discover a problem that you think may be covered by the warranty you MUST REPORT it in writing to the address below within thirty (30) days. Proof of purchase (an original sales receipt) from the original consumer purchaser must accompany all warranty claims. Warranty claims must also include a description of the problem, the purchaser's name, address, and telephone number. General inquiries can be addressed to ViewZ USA Customer Service at 1-888-998-4399. Warranty claims will not be accepted over the phone or by fax.

ViewZ USA
Attn: Warranty Claim
1030 N ARMANDO ST.,
ANAHEIM, CA 92806

How State Law Applies

THIS WARRANTY GIVES YOU SPECIFIC LEGAL RIGHTS, AND YOU MAY ALSO HAVE OTHER RIGHTS WHICH VARY FROM STATE TO STATE.

Disclaimer

ViewZ USA intends to make this manual accurate and complete. However, ViewZ USA makes no claim that the information contained herein covers all details, conditions or variations, nor does it provide for every possible contingency in connection with the installation or use of this monitor. The information contained in this document is subject to change without notice or obligation of any kind. ViewZ USA makes no representation of warranty, expressed or implied, regarding the information contained herein. ViewZ USA assumes no responsibility for accuracy, completeness or sufficiency of the information contained in this document.

Contact Us

NORTH AMERICA
1030 N ARMANDO ST.,
ANAHEIM, CA 92806
USA and Canada
Phone: 1-888-998-4399
Fax: 1-714-996-1138
Other Locations
Phone: (001) 888-998-4399
Fax: (001) 714-996-1138

© ViewZ USA